

GLAMOX *heating*

User Guide for CT- Remote Control

with thermostats SM and SF, and relay SX

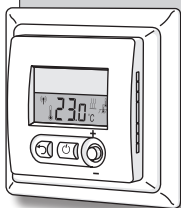
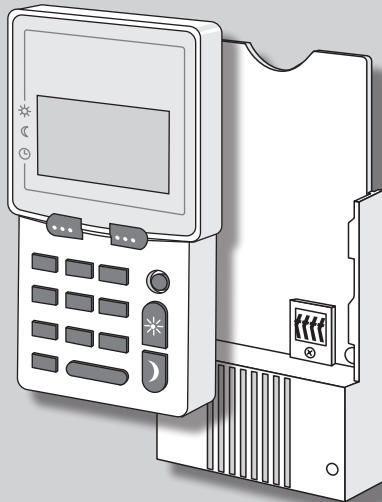

SM- / SF- / SX-

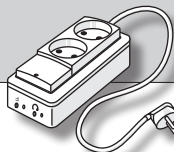

CO-e

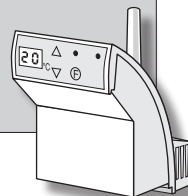

CR-

Important – before use

Situating the CT- remote control:

This should be placed as centrally as possible in the building. It should be mounted on a wall of wood, chipboard or plasterboard for maximum range. It should not be placed in a fuse box or a room of steel or reinforced concrete as this will reduce its range.

The range is normally 30–40 metres.

Fix the holder/charger and couple it to a 230 V supply.

Open the battery compartment at the back of the charger and press the loose battery connector in place (the battery may already be connected).

The battery is appr. 25% charged by the factory and must be fully charged when CT- is taken into use for the first time. Place CT- in the holder for charging. Make sure that the red lamp on the holder is lit. *The remote control must now charge for 12 hours or more before it is again taken out of the holder.*

CT- may be used normally while it is charging in the holder.

• **Operational reserve**

CT- may be used without it being in the holder. The reserve is up to 3–4 days of battery operation. When the battery is nearly empty, CT- will display a warning that battery capacity is low. Put the unit back in the holder for charging.

CT- will, after 3–4 days of battery operation, stop sending commands to heaters, wall thermostats or relays. It will though remember all programming, even after a long power cut, so this does not have to be entered again.

• **Longer breaks in operation**

If CT- is left to discharge for a long period, we advise disconnecting the battery by loosening the battery connector. This is to avoid discharging it completely.

• **Increased battery life**

To achieve long life for the battery, we recommend that, occasionally, it is allowed to discharge to the level when the warning is displayed. Do this once a year by removing CT- from its holder for 3–4 days.

• **Important**

If CT- is opened by an unauthorised person, the guarantee will be invalid. Guaranteed in accordance with consumer rights.

CT-Remote control

- 1 Antenna.
- 2 Weekdays, the number moves as the day is changed. 1 = Monday, 2 = Tuesday and so on.
- 3 24-hour column chart. Tall columns represent hours when normal temperature is maintained, or when a relay is switched on. Short columns represent hours when economy temperature is maintained, or when a relay is switched off.
- 4 Information (upper text line). The display shows: The figure 1 uppermost in the display tells that it is Monday. The time 05:00 is the start time for normal temperature, and 09:00 is the stop time. The displays shows two periods with tall columns representing normal temperature, here the second period is from 15:00 to 22:00.
- 5 Text showing the choices that may be made by pressing the option keys, as described below.
- 6 Option keys: These allow you to choose between the options given by the lower line of text (5). The text on the left is selected by the left-hand key, and the text on the right by the right-hand key.

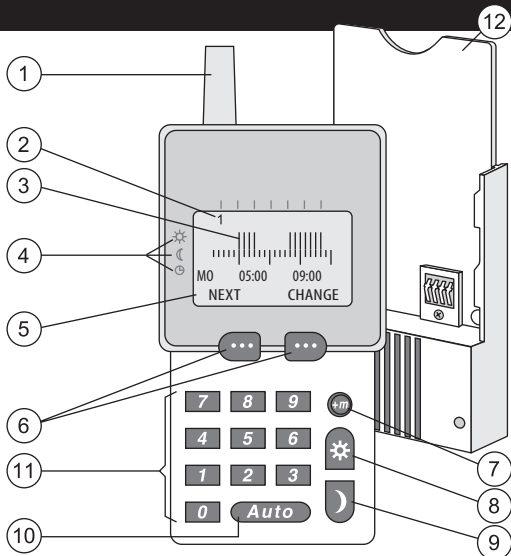

- 7 Minute adjuster: During programming, the start/stop times for economy temperature may be adjusted by 15 minute intervals.
- 8 Override key giving normal temp.
- 9 Override key giving economy temp.
- 10 Auto (Exit). Is used to return to the MENU-display. *NB! When Auto is pressed, anything that has been entered will not be saved.*
- 11 Numerical keys 1–9.
- 12 Holder and battery charger.

Getting started – quick guide

Congratulations on your choice of control system for regulating temperature, lighting and appliances.

Here, we will help you to get started quickly.

Connect CT to a 230 volt power supply and make sure that the thermostats and relays are also connected and in operation.

THE MENU OPTION KEYS

You will find two keys marked with three dots. The left-hand key is used to select the option shown directly over it in the display. Likewise, you choose the option shown on the right-hand side of the display with the right-hand key. If --, or 00 is shown in the display, you must type in a value with the numerical keys.

REGULATING TEMPERATURE

We assume that you wish to make a programme to regulate the heating in a living room. It is to be warm from 17:00 to 23:00 on weekdays, and from 08:00 to 24:00 at weekends. The temperature is to be set at 21°C during use, and 16°C at other times. At the weekend the room is kept warm from 07:00 till midnight.

PROGRAMMING

Assuming CT is displaying the start-MENU.

- Press the left-hand key until NEW PROGRAMME? is shown
- Press the right-hand option key for YES.
- Choose HEATING using the right-hand key. We let the living room be zone 1.
- Type the number 1 (01) and confirm with OK.
- Choose COLUMNS in order to set temperatures at intervals of one hour.
- Type in the numbers 1, 2, 3, 4 and 5, representing Monday to Friday. Confirm with OK.
- 22°C appears as the default setting, but we type 21 as our choice. Confirm with OK.
- For the economy temperature, we type 16.

Now, we see 24 columns, one for each hour of the day. The first column is flashing which means that we

should choose either 21 or 16 for the hour from midnight (00.00) to 1 a.m. (01.00).

We now press the 16°C option key 16 times until

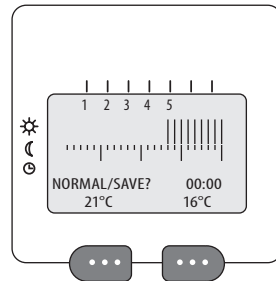

16:00 is displayed. (We start heating the room one hour before it comes into use.)

- Now press seven times on 21 and once on 16. CT- asks if we are SATISFIED? Confirm with YES
- Respond with YES to the question MORE DAYS?
- Type 6 and 7 for Saturday and Sunday. Press for OK.
- Choose 22°C and 16°C and press seven times for 16°C, and 07:00 is displayed.
- We allow heating up to start an hour before we intend using the room.
- Then press 22°C until all the columns are defined.
- SATISFIED? Press YES.
- MORE DAYS? Press NO.
- SAVED! appears and shows that we have made a programme for the living room in zone 1.
- MORE ZONES? Press NO.

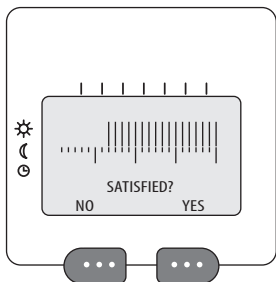

LINKING UP

We assume that there are one or more heaters in the living room, and we must now make sure that they are regulated by CT-.

- Press the left-hand option key until LINK UP? appears. Press YES.
- Type 1 (01) to select the zone. Press OK.
- The display shows PRESS F >5 S.
- Holding CT- near to the heater, press down on the F button for more than five seconds.
- When the number 01 flashes several times in the display, the heater is linked to CT-.
- Go to the next heater (if there are more heaters in the room) and repeat the procedure.
- Press FINISH when all the heaters in zone 1 are linked up.

SET THE CLOCK

- To set the clock, go to MAINTENANCE.
- Press YES, and then NEXT until SET CLOCK appears. Press YES.
- Type in the correct time under SET TIME --:--. Confirm with OK.
- SET DAY 1-7, where 1 is Monday, 2 Tuesday and so on. Type the number of the day.
- End with OK.

OPERATION

The thermostats will now set themselves to the temperature applying to the hour in question. You may press the red SUN or blue MOON on CT- to verify that the heaters are following your wishes. Press ALL when ALL/CHOOSE is displayed. Press FINISH to end the override and you return to the start-MENU.

We hope that this has helped you quickly understand how the system can be used, and we hope you enjoy exploring all the other functions that are described in this guide.

HINTS FOR THE USER

A function that can be very useful is TEMPORARY OVERRIDE. During occasional absences, holidays, weekends etc., you may programme the number of days and hours that the house, or parts of the house, are set to an extra low, energy saving temperature.





If you are away from home one weekend, leaving on Friday morning and returning on Sunday evening, the system may be set to 12 °C for two days and six hours.





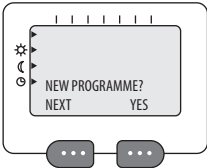

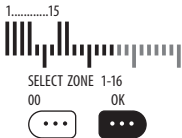



With an absence of a week, you may advantageously choose a temperature of 7 to 9 °C, and so save a considerable amount of energy – simply. AND, the system itself will end the economy setting at the appropriate time, making the house warm and cosy again at your return.



In the nursery, in schools or kindergartens, you will find the CENTRAL LOCK function (a function in the MAINTENANCE menu) very useful. When activated, this function makes it impossible to operate the thermostat's own controls. Everything is controlled by CT-.

NEW PROGRAMME FOR HEATING

Make a note of all the rooms where the heating is to be regulated. Give each room, or group of rooms, a zone number. All rooms that are to have the same cycle of heating may be allotted the same zone number. Note down the times that each zone is kept at comfort or economy temperature.

	<p>In order to make a new programme, press the left hand option key until NEW PROGRAMME? appears. Confirm with YES. If you change your mind, press AUTO to return to the start MENU.</p>
<p>SELECT ZONE-TYPE RELAY HEATING</p> 	<p>Press HEATING under SELECT ZONE-TYPE to make a programme that regulates heating.</p>
	<p>SELECT ZONE (choose a number from 1 to 16) Type the desired zone number and confirm with OK. (Heating zones that are already programmed are shown by tall columns.) Zone 1 is represented by the 1st column from the left, zone 2 by the 2nd column, and so on. If a zone number is already in use you will see IN USE displayed. Choose another number or delete the existing programme for this zone. (See DELETE PROG.)</p> <p>A zone may comprise a single room with one or more heaters or under-floor heating, or a group of rooms that are to have the same heating cycle.</p>
<p>PROGRAMME-TYPE TIME COLUMN</p> 	<p>Now you are given two choices for the method of entering the times for normal and economy temperature.</p> <p>Using COLUMN, you enter normal or economy temperature for the hours of the day by pressing a key for each hour. Using the (4m) key, you may programme 15 minute increments.</p> <p>Using TIME, you enter the start and stop times for periods of normal temperature.</p>
<p>SET DAY: 1-7</p> 	<p>SET DAY. Type the number(s) representing the day(s) that are to have the same heating cycle. Monday is represented by 1, Tuesday by 2, and so on. To remove a day from the display, type its number once more. The selected days are shown uppermost in the display.</p>





<p>1 2 3 4 5</p> <p>°C NORMTEMP 5-35</p> <p>22 OK</p> 	<p>Select normal temperature. The default setting, 22°C, is suggested. Type in another number if you desire a different temperature. Confirm with OK.</p>
<p>1 2 3 4 5</p> <p>°C SAVETEMP 5-30</p> <p>17 OK</p> 	<p>Select economy temperature: 17°C appears as the suggested setting. Type in another number if you desire a different temperature. Confirm with OK.</p>
 <p>SELECT! 00:00</p> <p>22°C 17°C</p> 	<p>SELECT: A column chart with 24 columns appears, one for each hour of the day. The first column is flashing and represents the first hour of the day, from 00:00 to 01:00. As an aid, every sixth hour is displayed taller, i.e. 05:00–06:00, 11:00–12:00, 17:00–18:00 and 23:00–00:00. By pressing the option keys under 22°C or 17°C on the display, you choose whether the hour from 00:00 to 01:00 is to set at normal or economy temperature. Start heating at normal temperature about an hour before the room comes into use. Similarly, make a setting for all 24 hours. The start time for the hour in question is displayed and the column flashes. If you desire times varying from whole hours, you may jump forwards in the 15 min. increments using the  key.</p>
 <p>SATISFIED ?</p> <p>NO YES</p> 	<p>SATISFIED? The column chart shows the day's cycle, with low columns representing when economy temperature is set and tall ones when normal temperature is maintained. When all 24 hours have been programmed with either normal or economy temperature, you will be asked if you are finished. Confirm by pressing YES. If you made a mistake in the programme, simply press NO and the cycle will be set again. The example shows normal temperature for the periods 05:00–08:00 and 15:00–23:00.</p>
<p>START-TIME ---:--</p> <p>CHANGE OK</p> 	<p>Type in the START TIME for the first period of normal temperature. Confirm with OK. NB! If you type in periods that overlap, they will be stored as one long period with the earliest and latest times as the start and stop times.</p> <p>To avoid such overlapping, it is a good idea to jot down the desired times before you enter them.</p>
<p>STOP-TIME ---:--</p> <p>CHANGE OK</p> 	<p>Type in the STOP-TIME for the period of normal temperature. Confirm with OK.</p>
<p>MORE CYCLES?</p> <p>NO YES</p> 	<p>MORE CYCLES? If further periods with normal temperature are desired, press YES. You may then set the start and stop times for a new period with normal temperature.</p>





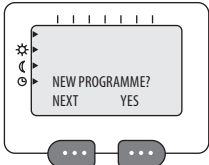

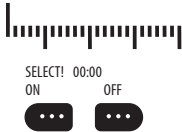

<p>SATISFIED?</p> <p>NO YES</p> 	<p>SATISFIED? If you are satisfied with the temperature programme, press YES. If not, press NO and the cycle may be set again.</p>
<p>MORE DAYS ?</p> <p>NO YES</p> 	<p>MORE DAYS? All the days of the week must be programmed if they are to have a daily cycle. Days that are not programmed will automatically be set to 17°C (the default economy temperature) for the whole day. If you press YES, you will return to SET DAY(S).</p>
<p>SAVED !!</p>	<p>SAVED! The moment you confirm that do not wish to programme any more days for the zone in question, SAVED! is displayed, and the zone is now programmed.</p>
<p>MORE ZONES?</p> <p>NO YES</p> 	<p>MORE ZONES?</p> <p>Finally you are asked if you wish to programme other zones. Choose with YES or NO. Pressing NO leads you back to the start MENU. Pressing YES will allow you again to choose HEATING or RELAY zones.</p>

NEW PROGRAMME FOR RELAY

Make a note of appliances and lighting that are to be switched on and off. Give each appliance, or group of appliances, a zone number. All appliances that are to work in step may be allotted the same zone number. Note down the times that each zone is to be switched on and off.

There are two versions of the relay. COG-e has a plug and lead for connecting to a power outlet. COG-e has twin sockets for powering appliances with a plug and lead. CXG is for permanent installation.





	<p>To make a programme, press the left hand option key until NEW PROGRAMME? appears. Confirm by pressing YES.</p>
	<p>Press RELAY under SELECT ZONE-TYPE to make a programme that regulates relays.</p>
	<p>SELECT ZONE (relay zones must have a number from 17 to 24) Type the desired zone number and confirm with OK. Zones that are already programmed are shown by tall columns. Zone 17 is represented by the 17th column from the left, zone 18 by the 18th column, and so on. If a zone number is already in use you will see IN USE displayed. Choose another number or delete the existing programme for this zone. (See DELETE PROG.)</p> <p>A zone may comprise a single appliance, or several that are to be switched on and off at the same times.</p>
	<p>Now you are given two choices for the method of entering the times that the relay is to be switched on and off.</p> <p>With COLUMN, you choose ON or OFF for the day's 24 hours by pressing a key for each hour. Using the (+15) key, you may programme 15 minute increments.</p> <p>With TIME, you type in the start and stop times for when a relay is to be switched on.</p>
	<p>SET DAYS. Type the number(s) representing the day(s) that are to have the same on/off cycle. Monday is represented by 1, Tuesday by 2, and so on. To remove a day from the display, type its number twice. The chosen days are shown uppermost in the display.</p>

<p>1 2 3 4 5</p> 	<p>SELECT CYCLE. A column chart with 24 columns appears, one for each hour of the day. The first column is flashing and represents the first hour of the day, from 00:00 to 01:00. As an aid, the column for every sixth hour is taller, i.e. 05:00–06:00, 11:00–12:00, 17:00–18:00 and 23:00–00:00. By pressing the option keys under ON or OFF on the display, you choose whether the relay is to be switched on or off for the hour 00:00–01:00. This procedure is repeated for each of the 24 hours. The start time for each hour is displayed, and the column flashes. If you desire times other than whole hours, you may jump forwards in 15 minute increments by pressing the Ⓜ key.</p>
<p>1 2 3 4 5</p> 	<p>SATISFIED? The column chart shows the day's cycle, with low columns representing when the relay is switched off and tall columns when it is switched on. When all 24 hours have been programmed with either ON or OFF, you will be asked if you are finished. Confirm by pressing YES. If you made a mistake in the programme, simply press NO and the cycle may be set again. The example shows ON for the periods 05:00–08:00 and 15:00–23:00.</p>
<p>START-TIME ---</p> <p>CHANGE OK</p> 	<p>Type in the START-TIME for the first ON period. Confirm with OK. NB! If you type in periods that overlap, they will be stored as one long period with the earliest and latest times as the start and stop times. To avoid such overlapping, it is a good idea to jot down the desired times before they are entered.</p>
<p>STOP-TIME ---</p> <p>CHANGE OK</p> 	<p>Type in the STOP-TIME for the period with ON. Confirm with OK.</p>
<p>MORE CYCLES?</p> <p>NO YES</p> 	<p>MORE CYCLES? If further periods with the relay ON are desired, press YES. You may then set the start and stop times for a new period with the relay switched ON.</p>
<p>SATISFIED?</p> <p>NO YES</p> 	<p>SATISFIED? If you are satisfied with the programming, press YES. If not, press NO and the cycle may be set again.</p>
<p>MORE DAYS?</p> <p>NO YES</p> 	<p>MORE DAYS? All the days of the week must be programmed if they are to have a daily cycle. Days that are not programmed will automatically be set to OFF (default) for the whole day. If you press YES, you will return to SET DAY(S).</p>
<p>SAVED!!</p>	<p>SAVED! The moment you confirm that do not wish to programme any more days for the zone in question, SAVED! is displayed, and the zone is now programmed.</p>
<p>MORE ZONES?</p> <p>NO YES</p> 	<p>MORE ZONES? Finally you are asked if you wish to programme other zones. Choose with YES or NO. Pressing NO leads you back to the start MENU. Pressing YES will allow you again to choose HEATING or RELAY zones.</p>

LINK UP

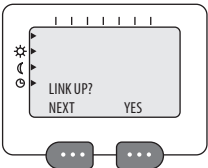







LINK UP enables you to decide which receivers will follow the programming for each zone. Only when a receiver is linked to a zone, will it be able to follow the commands transmitted by CT-. When **LINKING UP** is in progress your receivers learn to follow instructions from your remote control only. In this way, systems in neighbouring houses will not interfere with each other. Also, several systems may be used in the same building at the same time.

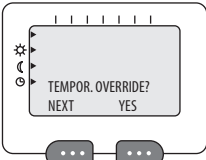







Put CT into Link-up mode. We recommend that you make programmes for all zones before linking the thermostats to the remote control. When this is done, go to **LINK UP** in the remote control menus. It is best to take the remote control into the room where the thermostat in question is located. Type in the zone number when **CHOOSE ZONE** is displayed on the remote control, and press **OK** to confirm. Then, **PRESS F** is displayed. >5s.

	<p>LINK UP? Press the left-hand option key until LINK UP? appears in the display. Confirm with YES.</p>
	<p>SELECT ZONE. You will now see a column chart with 24 columns, each representing a zone. Zone 1 is the first column from the left, zone 2 is the 2nd column, and so on. Tall columns represent zones that are programmed. Heating zones are from 1 to 16 and relay zones from 17 to 24.</p> <p>Type in the desired zone number. Confirm with OK.</p>
 <p>SF, SM, SX</p>	 <p>CR-</p>
	<p>For CR-, plug-in thermostats, and CO-e: Press and hold down the button marked F for more than 5 seconds. The display will flash and show the chosen zone. Link-up is now successful.</p> <p>For SF-, SM- and SX-: Press in and hold down the joystick until 1rF is displayed. Press once lightly on the joystick and the thermostat shows the zone number that you have chosen on the remote control. Link-up is now successful.</p> <p>CT will stay in link-up mode for appr. 2 minutes. During this time, several units may be linked to the same zone. For further zones, press NEXT.</p>

TEMPORARY OVERRIDE





Should you, for shorter or longer periods, need to set a fixed temperature in one or more rooms, **TEMPORARY OVERRIDE** will allow you to do this. For example, during holidays, the whole house (or selected rooms) may be set to an economy temperature of e.g. 10°C. Similarly, relays may be set to ON or OFF.





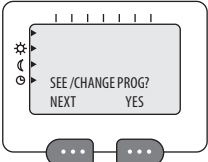

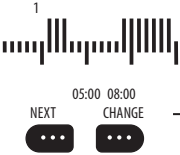
	<p>Press the left-hand option key until TEMPORARY OVERRIDE appears. Confirm with YES.</p>
<p>NUMBER OF DAYS? 00 OK</p> 	<p>Type in the NUMBER OF DAYS you desire. Type 0 if it is not a whole day. Confirm with OK.</p>
<p>NUMBER OF HOURS? 00 OK</p> 	<p>Type in the NUMBER OF HOURS you desire. Confirm with OK.</p>
<p>SELECT ZONE-TYPE RELAY HEATING</p> 	<p>SELECT ZONE-TYPE. Choose as to whether you want to regulate a zone for heating or relay controlled appliances. If you select HEATING now, you may return later and select RELAY.</p>
<p>SELECT TEMP 5-35 00 OK</p> 	<p>Now you choose the temperature that is to be maintained during the period. If you intend to regulate several zones, they will all be set to this temperature.</p>
<p>08°C : 00d 08h CHANGE OK</p> 	<p>Confirm the chosen temperature. If all is satisfactory, press YES.</p>
<p>SELECT ZONE(S) ALL SELECT</p> 	<p>SELECT ZONE(S). If you choose ALL, all zones that are programmed will be overridden.</p>
<p>SELECT ZONE 1-16 00 OK</p> 	<p>SELECT ZONE. Here, you indicate the heating zone you wish to be set at an economy temperature for the chosen period. Type in its number and confirm with OK.</p>



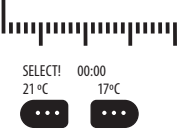

<p>MORE ZONES? NO YES</p> 	<p>MORE ZONES? If you wish to regulate more zones, press YES. If you press NO, the period of overriding will begin for the chosen zone(s).</p>
<p>● OVERRIDE ACTIVE! MORE CANCEL</p> 	<p>Here, you may choose to manually end a PERIOD of override. Press CANCEL. If you wish to put more zones under PERIODIC CONTROL, press MORE. Zones that are temporarily overridden will flash in the display.</p>
<p>SELECT ZONE-TYPE RELAY HEATING</p> 	<p>SELECT ZONE-TYPE. Press the option key beneath your choice.</p>
<p>● RELAY STATE? ON OFF</p> 	<p>Now you choose whether the relay is to be switched ON or OFF for the period. If you put more zones under periodic control, these will all have the same STATE as chosen here.</p>
<p>OFF : 08d 08h CHANGE OK</p> 	<p>Confirm the temporary override for the relays here. If the settings are now as required, press YES.</p>
<p>SELECT ZONE(S) ALL SELECT</p> 	<p>SELECT ZONES. Choosing "ALL" will entail that all heating or relay zones will be overridden. Choosing SELECT will allow you to specify one or more heating zones you wish to override.</p>
<p>SELECT ZONE 17-24 00 OK</p> 	<p>SELECT ZONES. If you choose ALL, all zones that are programmed will be overridden.</p>
<p>MORE ZONES? NO YES</p> 	<p>MORE ZONES? If you wish to regulate more zones, press YES. If you press NO, the period of overriding will begin for the chosen zone(s).</p>
<p>● OVERRIDE ACTIVE! MORE CANCEL</p> 	<p>Here, you may choose to manually end a period of override. Press CANCEL. If you wish to put more zones under TEMPORARY OVERRIDE, press MORE. Zones that are temporarily overridden will flash in the display.</p>

SEE / CHANGE PROGRAMME FOR HEATING (ZONE 1–16)

This sequence shows you how to review current programming and make alterations, if desired. You are shown each day successively, with normal and economy temperature settings, and when heaters are programmed with them. Along the way, you can change any settings for a particular day, or several days together.

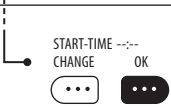



	<p>SEE/CHANGE PROG. To review and change programming, press the left-hand option key until SEE/CHANGE PROG? appears. Confirm with YES. If you change your mind, press AUTO to return to the START menu.</p>
<p>SELECT ZONE-TYPE RELAY HEATING</p> 	<p>Press HEAT under SELECT ZONE TYPE to review heater settings.</p>
<p>1.....15</p> 	<p>CHOOSE ZONE (heating zones have numbers from 1 to 16) Type the desired zone number and confirm with OK. Heating zones that are programmed are displayed with tall columns. Zone 1 is represented by column 1 from the left, zone 2 by column 2 and so on.</p> <p>A zone may comprise one room with one or more heaters or under floor heating, or a group of rooms that have the same daily heating cycle.</p>
<p>1</p> 	<p>The figure 1 uppermost in the display tells you that you are viewing Monday's programme. The first period with normal temperature is shown by the start and stop times. Press NEXT to see the start/stop times of further periods with normal temperature. When all periods for day 1 have been shown, you will jump automatically to the next day. Continue to press NEXT until you have reviewed all the days. When you choose CHANGE, you may change the programming for a single day, or a group of days.</p>
<p>MORE ZONES? NO YES</p> 	<p>If you press NO, you will return to the start MENU. Press YES and you may choose another zone to review.</p>
<p>SET DAYS: 1-7</p> 	<p>SET DAYS. Type the number(s) of the day(s) that are to have the same heating cycle. Monday is 1, Tuesday is 2, and so on. To remove a day from the display, press twice on its number key. The chosen days appear uppermost in the display.</p>



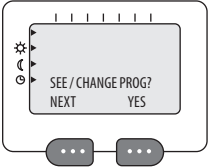

<p>CHANGE TEMP CYCLE</p> 	<p>Now you may choose to change either the temperature settings or the daily cycles.</p>
<p>°C NORMTEMP 5-35 22 OK</p> 	<p>NORMTEMP. Set normal temperature: The default setting is 22°C and appears as a suggestion. Type in other figures if you desire a different temperature. Confirm with OK.</p>
<p>°C SAVETEMP 5-30 17 OK</p> 	<p>SAVETEMP. Set the economy temperature: The default setting, 17°C, appears as a suggestion. Type in other figures if you desire a different temperature. Confirm with OK. You may now go on to alter the times.</p>
<p>SAVED !!</p>	
<p>CHANGE CYCLE NO YES</p> 	<p>When the new temperature settings are saved, you will be asked if you wish to reprogramme the times. Press NO and you return to review your last alteration. Press YES and you go to...</p>
<p>PROGRAMME-TYPE TIME COLUMN</p> 	
	<p>Set the daily cycle. A column chart with 24 columns appears, one for each hour of the day. The first column is flashing and represents the first hour of the day, from 00:00 to 01:00. As an aid, every sixth hour is shown taller, i.e. 05:00–06:00, 11:00–12:00, 17:00–18:00 and 23:00–00:00. By pressing the option keys under 22°C or 17°C on the display, you SELECT whether the hour from 00:00 to 01:00 is to be set at normal or economy temperature. Start heating at normal temperature about an hour before the room comes into use. Continue to make a setting for all 24 hours. The start time for the hour in question is displayed and the column flashes. If you desire times varying from whole hours, you may jump forwards at 15 min. increments using the  key.</p>
	<p>SATISFIED? The column chart shows the day's cycle, with low columns representing when economy temperature is set and tall ones when normal temperature is maintained. When all 24 hours have been programmed with either normal or economy temperature, you will be asked if you are finished. Confirm by pressing YES. If you made a mistake in the programme, simply press NO and the cycle may be set again. The example shows normal temperature for the periods 05:00–08:00 and 15:00–23:00. When you confirm with YES, all changes are stored and you can move on.</p>
<p>SAVED</p>	<p>After SAVED you arrive again at NEXT or CHANGE. Go to the NEXT day or quit with AUTO.</p>

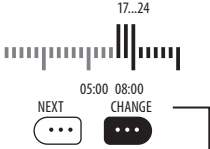
 <p>START-TIME ---:-- CHANGE OK [] []</p>	<p>Type in the START TIME for the first period of normal temperature. Confirm with OK. NB! If you type in periods that overlap, they will be stored as one long period with the earliest and latest times as the start and stop times. To avoid such overlapping, it is a good idea to jot down the desired times before you enter them.</p>
 <p>STOP-TIME ---:-- CHANGE OK [] []</p>	<p>Type in the STOP time for the period of normal temperature. Confirm with OK.</p>
 <p>MORE CYCLES? NO YES [] []</p>	<p>MORE CYCLES? If you wish to set more periods of normal temperature, press YES. You may then enter the START and STOP times for the period.</p>
 <p>SATISFIED? NO YES [] []</p>	<p>SATISFIED? If you are satisfied with programming, confirm with YES. If you change your mind, press NO and you can type in new periods.</p>
<p>SAVED !!</p>	<p>When your changes have been SAVED! you will return to NEXT in the zone in question, from the (first) day you made changes to. Go to the next day and make revisions here if necessary.</p>

SEE / CHANGE PROGRAMME FOR RELAY (ZONE 17–24)

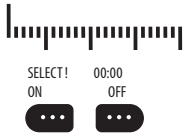
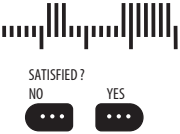

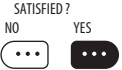

This sequence shows you how to review current programming of relays and make alterations, if desired. You are shown each day successively, and when relays are switched ON and OFF. Along the way, you can change any settings for each day, or several days together.

	<p>To SEE or CHANGE a programme, press the left-hand option key until SEE/CHANGE PROG? appears. Confirm with YES.</p>
	<p>Choose RELAY under SELECT ZONE-TYPE to review relay settings.</p>
	<p>SELECT ZONE (relay zones must have a number from 17 to 24) Type the desired zone number and confirm with OK. Relay zones that are programmed are displayed with tall columns. Zone 17 is represented by column 17 from the left, zone 18 by column 18 and so on. A zone may comprise one or more relays that are to have the same daily cycle.</p>
	<p>The figure 1 uppermost in the display tells you that you viewing Monday's programme. The first period with the relays switched on, is shown by the start and stop times. Press NEXT to see the start/stop times of further ON periods. When all periods for day 1 have been shown, you will jump automatically to the next day. Continue to press NEXT until you have been through all the days. When you choose ALTER, you may change the programme for a single day, or a group of days.</p>
	<p>Pressing NO returns you to the start MENU. Press YES and you may choose another zone to review.</p>
	<p>SET DAYS. Type the number(s) of the day(s) that are to have the same ON/OFF cycle. Monday is 1, Tuesday is 2, and so on. To remove a day from the display, press once more on its number key. The chosen days appear uppermost in the display.</p>

	<p>Now you are given two alternatives for the method of entering ON/OFF times.</p> <p>Using columns, you enter ON or OFF for each of the day's 24 hours, by pressing a key once for each hour.</p> <p>Choosing TIME lets you type in the start and stop times for periods the relays are to be switched on.</p>
	<p>SET DAILY CYCLE. A column chart with 24 columns, one for each hour of the day, appears. The first column is flashing and represents the first hour of the day, from 00:00 to 01:00. As an aid, every sixth hour is shown taller, i.e. 05:00–06:00, 11:00–12:00, 17:00–18:00 and 23:00–00:00. By pressing the option keys under ON or OFF on the display, you choose whether the hour from 00:00 to 01:00 is to be set with relays switched ON or OFF. Make a choice for all 24 hours. The start time for the hour in question is displayed and the column flashes. If you desire times varying from whole hours, you may jump forwards in 15 min. increments by pressing the (+m) key.</p>
	<p>SATISFIED? The column chart shows your chosen daily cycle with low columns representing when the relays are switched off, and tall columns for when they are on. When all 24 hours have been programmed, you are asked if you are finished. Confirm with YES. If you wish to make changes, press NO, and the cycle may be entered again. The example shows relays ON during the periods 05:00–08:00 and 15:00–23:00.</p>
<p>SAVED!!</p>	
	<p>Type in the START-TIME for the first ON period. Confirm with OK.</p> <p>NB! If you type in periods that overlap, they will be stored as one long period with the earliest and latest times as the start and stop times. To avoid such overlapping, it is a good idea to jot down the desired times before you enter them.</p>
	<p>Type in the STOP-TIME for the ON period. Confirm with OK.</p>
	<p>MORE CYCLES? If you want further periods with the relays switched ON, press YES. You may then type in the START and STOP times for a new period.</p>
	<p>SATISFIED? If you are satisfied with the programming, confirm with YES. If you wish to make changes in the cycle, press NO, and you can type in the correct periods.</p>
<p>SAVED!!</p>	

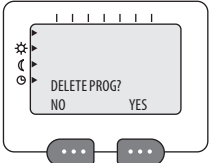
DELETE PROGRAMME

Programmes that are no longer in use should be deleted so that they do not take up unnecessary space in the system, and so you get a correct overview when you use SEE STATUS to review current programming.





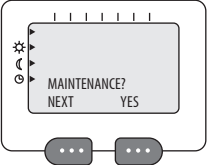

 <p>The LCD screen displays 'DELETE PROG?' at the top. Below it are two options: 'NO' and 'YES'. To the left of the screen are three icons: a sun, a moon, and a clock. Below the screen are two buttons, each with three dots.</p>	<p>To delete a programme, press the left-hand option key until DELETE PROG? appears. Confirm with YES.</p>
 <p>The LCD screen displays 'SELECT ZONE' at the top. Below it is a bar chart with 24 columns of varying heights. Below the chart are two options: '00' and 'OK'. Below the screen are two buttons, each with three dots.</p>	<p>SELECT ZONE. Tall columns represent programmed zones (the example shows heating zones 1–2–3–4 and relay zones 17–18). Type in the zone number and confirm with OK.</p>
 <p>The LCD screen displays 'DELETE PROG?' at the top. Below it are two options: 'NO' and 'YES'. Below the screen are two buttons, each with three dots.</p>	<p>Now you are given the choice to delete or not. Pressing NO returns you to the start MENU.</p>
 <p>The LCD screen displays 'DELETE MORE?' at the top. Below it are two options: 'NO' and 'YES'. Below the screen are two buttons, each with three dots.</p>	<p>DELETE MORE? The column chart displays the remaining zones. If you wish to delete more zones, press YES. If not, return to the start MENU by pressing NO.</p>

MAINTENANCE SELECT LANGUAGE SET CLOCK PINCODE CENTRAL LOCK MODE SEE VERSION

Here, you may set the clock, choose a language, take into use a PIN-code to limit access and use of CT-, activate central locking of all linked units, choose normal or office mode, and check the software version.

This version of the CT remote control already has a PIN-code, but it is not activated. In the menu PINCODE you can choose whether it is active or not. When the code is active, it must be entered every time CT- is used. If you wish to make your own PIN-code, this is described under. If you want only those who know the system's PIN-code to have access to programming and reprogramming, you should activate the PIN-code immediately. The code should be learnt by heart or kept in a secure place.

	<p>Press the left-hand option key until MAINTENANCE appears. Confirm with YES.</p>
<p>SELECT LANGUAGE? NEXT YES ⋮ ⋮</p>	<p>LANGUAGE? Here you may choose between English, Norwegian, Swedish and Finnish. [English, German, Polish, Lithuanian] [English, Bulgarian, Serbo-Croat, Slovenian] [English, Latvian, Estonian, Ukrainian]</p>
<p>ENGLISH > NORSK > SVENSKA > SUOMI > NEXT YES ⋮ ⋮</p>	<p>Press NEXT to flip through the different languages. ENGLISH? NORSK? SVENSKA? SUOMI? Press YES for your preferred language. When a language is chosen, the software version of your CT- is displayed, and CT- returns to the start MENU.</p>
<p>SET CLOCK? NEXT YES ⋮ ⋮</p>	<p>SET CLOCK? Confirm with YES if you wish to set the clock and day.</p>
<p>SET TIME: --:-- CHANGE OK ⋮ ⋮</p>	<p>SET TIME. Type in the correct time (00:00 – 23:59), and confirm with OK.</p>
<p>SET DAYS: 1-7 ⋮ OK ⋮ ⋮</p>	<p>SET DAY. When the correct day is chosen, CT- returns you to the start-MENU.</p>

<p>PINCODE? NEXT YES</p> 	<p>PINCODE? Confirm with YES if you wish activate/deactivate or change the PIN-code. This is to avoid unauthorised use of CT-. When activated, the code must always be entered to gain access to the system.</p>
<p>TYPE PINCODE ----</p>	<p>When you choose the PINCODE-menu, you must type in the correct pincode for the CT- in question in order to go any further.</p>
<p>ACTIVATE PINCODE NO YES</p> 	<p>ACTIVATE PINCODE. By pressing YES, CT- will not be able to be used by anyone who does not know the PIN-code. If NO is pressed, CT- may be used by anyone with access to it.</p>
<p>CHANGE PINCODE! NO YES</p> 	<p>CHANGE PINCODE? If you wish to change the current PIN-code, press YES. Pressing NO will return you to the start-MENU, and the present code will remain valid.</p>
<p>TYPE PINCODE! ----</p>	<p>TYPE PINCODE! Type in the four numbers that accompany CT- (the default code is 0000). If you want the code to be confidential, it should be personalised</p>
<p>REPEAT PINCODE! ----</p>	<p>REPEAT PINCODE. To make sure that the code is correct you are asked to type in once more.</p>
<p>CENTRAL LOCK? NEXT YES</p> 	<p>CENTRAL LOCK? Confirm with YES if you wish to lock all units so that they may only be regulated by CT-. This is to prevent unauthorised tampering with the units themselves. An activated lock allows the units to be regulated by CT- only. Linked units will show that they are locked by two lines in the display, when their controls are tampered with.</p>
<p>ACTIVATE LOCK? NO YES</p> 	<p>ACTIVATE LOCK? If the lock is activated, none of the linked units (heaters or relays) may be altered locally. The main switch (on/off) will still function.</p>
<p>MODE OFFICE NORMAL</p> 	<p>Select OFFICE or NORMAL. When you choose OFFICE, the red “HOT-KEY” will set CT to provide comfort temperature for five hours, followed by the normal CT programme. This is typically used when working overtime.</p>
<p>SEE VERSION? NO YES</p> 	<p>SEE VERSION? Confirm with YES if you wish to review which software version is in use. Please state this when enquiring about service, upgrades, etc.</p>

You may quit at any time, without activating any of the functions, by pressing Auto.

Description of relay unit (CO-e)

- 1. Main switch (0/1).** Plug for wall socket acts as main switch.
- 2. Function key.** The function key “F” has several uses:
 - To link up the relay unit to your CT- remote control. See the section on linking up.
 - To make CO-e receive commands from the CT- remote control or not.
- 3. Lamp for radio reception.** When CO-e is linked to CT- and the green lamp is lit, the unit is being regulated by CT-.
- 4. Local control.** If you wish to regulate CO-e by means of its own controls alone, the green lamp for radio reception must be dimmed (controlled by the “F” key). Using the ◡ key, CO-e may now be switched on and off.
- 5. Lamp for “on/off”.** The red lamp by the key lights when the unit is switched on.
- 6. Control of zone linking.** Linking to a zone may be controlled by pressing in the “F” key and then the ◡ key whilst “F” is held in. Release both keys. The red lamp (◡ lamp) will afterwards flash a certain

number of times denoting which zone the unit belongs to.

1 flash = relay zone 17

2 flashes = relay zone 18

...and so on up to...

8 flashes = relay zone 24

- 8. Central locking.** If the relay unit’s lamps are both flashing (both lamps flash for appr. five seconds), the unit is locked at CT- to avoid tampering. It may be unlocked only at CT-.

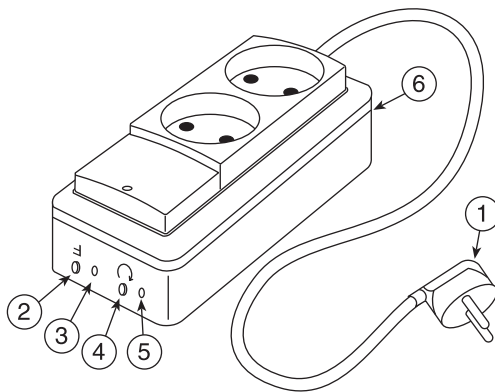

Description of floor thermostat (SF-)

1 Main switch (two-poled)

When SF is switched on, all symbols are displayed. Then sF1.0 [s(oftware) F(floor) 1.0 (version number)]. Then the zone number is shown followed by the chosen temperature, the antenna symbol and chosen sensor.

2 Joystick

To make choices in the menus, hold down the joystick for appr. 5 seconds. Release when the first menu is displayed. You may now choose a menu from 1 to 9 by gently pressing the joystick towards +. (Pressing towards – will take you back again.) When the desired menu is displayed, press the joystick once and the display flashes to confirm your choice. You may now choose between various settings by pressing gently towards + or –. When your final choice is made, press the joystick once to confirm it. When you have finished, exit the menus by pressing the return button. The system will otherwise finish automatically after about 30 seconds.

3 Return button

By pressing the return button you will exit all menus and return to normal operation with active radio reception, even if manual control was previously selected.

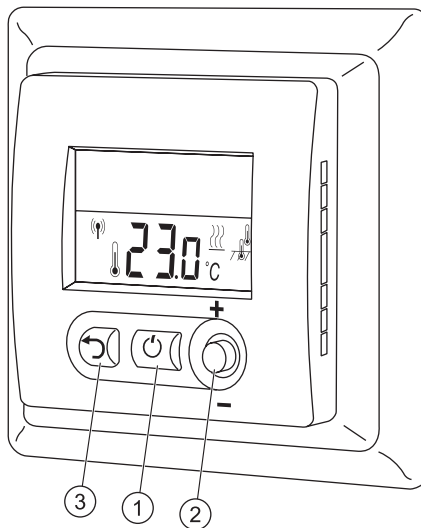

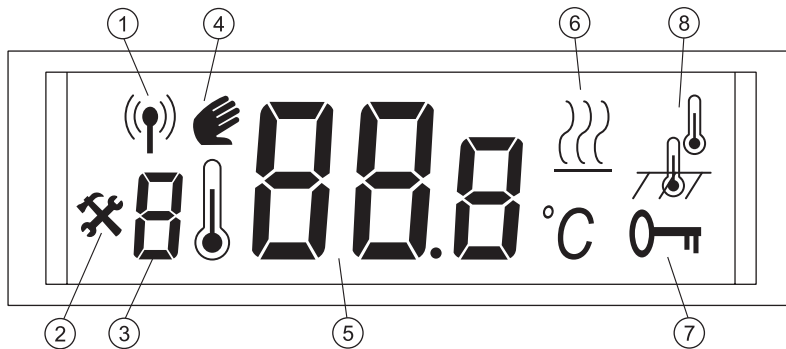

Display overview. When you first switch on you will see all the symbols used by the displayed. In order to appreciate the various functions, we recommend that you get to know the symbols and what they represent.





- 1 Antenna, displayed when SF is listening for a signal from the remote control.
- 2 Symbol denoting that the menu choice is active.
- 3 Shows the number of the chosen menu.
- 4 Hand symbol means that manual control is in operation.
- 5 Large characters show the zone number, temperature or menu text.
- 6 Indicator showing that the element is currently heating.



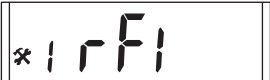

- 7 Key symbol indicates that the thermostat may only be regulated by the remote control.
- 8 Shows choice of room sensor or floor sensor.

Choosing manual control. To go over to manual control, first press the joystick towards + for more than 5 seconds. The hand symbol appears and the set temperature will increase as long as the joystick is pressed towards +. Release the joystick and press towards + or – to obtain your desired temperature. To go from manual override back to remote control, press the return button and the antenna symbol denoting remote control appears. The thermostat is again controlled by the remote control CT, which transmits signals every 12 minutes to keep all receivers updated.

How to access the menus

Hold the joystick down for more than 5 seconds until the display shows 1rF. Press the joystick gently towards + to browse through the menus until you reach the one you wish to review or change, then press down on the joystick to select it. The display will start flashing and you can make your change by pressing gently towards + or -. Finish by pressing the joystick down once to confirm your choice. You can continue to review other menus by pressing the joystick towards + or -. Exit the menus by pressing the return button.

	<p>Menu 1 – [1rF] – link up to the remote control CT Put the remote control into LINK UP mode. On SF, press in and hold down the joystick until 1rF is displayed. Press the joystick lightly once and the thermostat shows the zone number chosen on the remote control. Link-up is now successful.</p>
	<p>Menu 2 – [2bP] – selecting the method of control The display shows bP, alternatively Hys.</p> <p>bP (proportional band) means that the thermostat switches on and off within a 10 minute period. With little need for heat, the thermostat will switch off for a longer period and on for a shorter one. The opposite will apply when it is cold and the need for heating greater. Together, the on and off periods will always amount to 10 minutes.</p> <p>Hys (hysteresis) means that the thermostat will switch off when the temperature reaches 0.5°C over the set temperature, and switch on again when it sinks to 0.5°C under the set temperature.</p>
	<p>Menu 3 – [3 0.0 °C] – calibration when the built-in sensor is selected If there is a large deviation between the set temperature and the actual room temperature, SF can be calibrated. If the room is too cold, calibrate using + to get a higher value than 0. If too warm, calibrate using – to get a lower value than 0. (Before calibrating, the room should be stable, i.e. the thermostat should have been in operation for at least 10–12 hours. Avoid airing the room and opening doors and windows or switching other heat sources on and off during this period. Under-floor heating is often sluggish to regulate, and it may take a longer period to achieve stability, often 24 hours or more with cables set in concrete.)</p>
	<p>Menu 4 – [4 0.0 °C] calibration when a floor sensor or wall-mounted sensor is selected If there is a large deviation between the set temperature and the actual room temperature, SF can be calibrated. If the floor (room) is too cold, calibrate using + to get a higher value than 0. If too warm, calibrate using – to get a lower value than 0. (Before calibrating, the room should be stable, i.e. the thermostat should have been in operation for at least 10–12 hours. Avoid airing the room and opening doors and windows or switching other heat sources on and off during this period. Under-floor heating is often sluggish to regulate, and it may take a longer period to achieve stability, often 24 hours or more with cables set in concrete.)</p>
	<p>Menu 5 – [5 Sen] – selecting sensor(s). Select both for limiting the temperature in wooden flooring The choice of wall-mounted or floor sensor is shown by the symbol for floor sensor. If you choose the floor sensor when no such sensor is connected, you see an error report, Err. Connect an external sensor, or go to the menus and make another selection.</p>

	<p>Menu 6 – [6L18] – setting the lowest temperature for a floor sensor or wall-mounted sensor Select the lowest desired temperature for where the sensor is situated. (Range: 5°C up to 1°C under that which is selected as the maximum temperature limit.)</p>
	<p>Menu 7 – [7H28] – setting the maximum temperature for a floor sensor (or wall-mounted sensor) – used to avoid damage to wooden and parquet flooring from too high temperatures. Set the highest possible temperature that may be reached where the sensor is situated. Clarify with the flooring supplier what the recommended maximum temperature is. This is often 28°C for wooden floors and parquet. (Range: from 1°C over the minimum set point chosen in menu 6, up to 40°C.)</p>
	<p>Menu 8 – [8CL0] – compensating for various outputs For the best regulation when using the internal sensor, the thermostat must know how large an output the heating cable has.</p> <p>Choose a value for CL:</p> <ul style="list-style-type: none"> 0 = under 500 watts 1 = 500–1000 watts 2 = 1000–1500 watts (default setting) 3 = 1500–2000 watts 4 = 2000–2500 watts 5 = 2500–3000 watts 6 = over 3000 watts (NB! Maximum load = 3500 watts)
	<p>Menu 9 – [9FAc] – revert all settings to the factory default NB! This menu will revert all settings back to the factory default settings. If you do not know how values will be affected, do not use this menu without first studying the following:</p> <p>The default factory values are:</p> <ul style="list-style-type: none"> 1 = Zone 3 2 = bB proportional band regulation 3 = 0.0°C calibration of built-in sensor 4 = 0.0°C calibration of floor sensor (wall sensor) 5 = built-in sensor 6 = minimum temperature limit 18°C 7 = maximum temperature limit 28°C 8 = compensated for output load 1000–1500 watts 9 = FAc (no options) <p>When menu 9 is entered, press once lightly on the joystick. The display will flash “NO”. Pressing the joystick towards + selects NO, and pressing towards – selects Yes. When your choice has been made, press the joystick in once to store it.</p>

Description of the wall-mounter master thermostat (SM-)

1 Main switch (two-poled)

When SM is switched on, all symbols are displayed. Then s by s П1.0 [s(oftware) (П=master) 1.0 (version number)]. Then the zone number is shown followed by the chosen temperature, the antenna symbol and chosen sensor.

2 Joystick

To make choices in the menus, hold down the joystick for appr. 5 seconds. Release when the first menu is displayed. You may now choose a menu from 1 to 9 by gently pressing the joystick towards +. (Pressing towards – will take you back again.) When the desired menu is displayed, press the joystick once and the display flashes. You may now choose between various settings by pressing gently towards + or –. When your final choice is made, press the joystick once to confirm it. The display shows your choice without flashing, and you can move to other menus to make further selections. When you have finished, exit the menus by pressing the return button. The system will otherwise finish automatically after about 30 seconds.

3 Return button

By pressing the return button you will exit all menus and return to normal operation with active radio reception, even if manual control was previously selected.

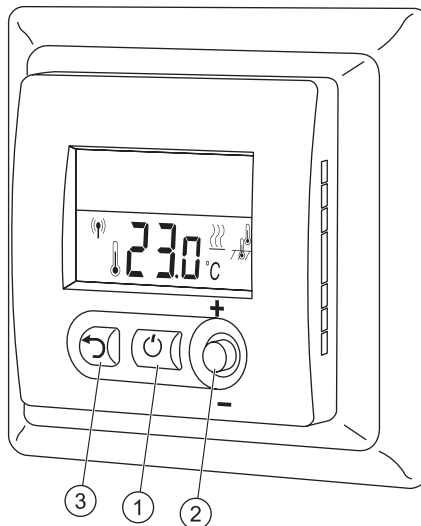

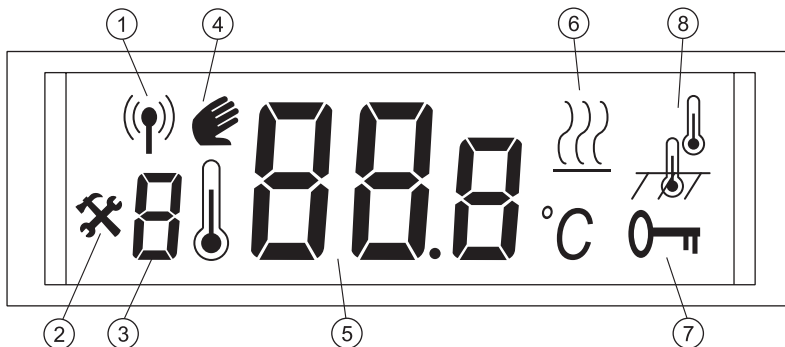

Display overview. When you first switch on you will see all the symbols used by the displayed. In order to appreciate the various functions, we recommend that you get to know the symbols and what they represent.





- 1 Antenna, displayed when SF is listening for a signal from the remote control.
- 2 Symbol denoting that the menu choice is active.
- 3 Shows the number of the chosen menu.
- 4 Hand symbol means that manual control is in operation.
- 5 Large characters show the zone number, the temperature or menu text.
- 6 Indicator showing that the element is currently heating.
- 7 Key symbol indicates that the thermostat may only be regulated by the remote control.





- 8 Shows choice of room sensor or floor sensor.

Choosing manual control. To go over to manual control, first press the joystick towards + for more than 5 seconds. The hand symbol appears and the set temperature will increase as long as the joystick is pressed towards +. Release the joystick and press towards + or – to obtain your desired temperature. To go from manual override back to remote control, press the return button and the antenna symbol denoting remote control appears. The thermostat is again controlled by the remote control CT, which transmits signals every 12 minutes to keep all receivers updated.

How to access the menus

Using the joystick. Hold the joystick down for more than 5 seconds until the display shows 1rF. Press the joystick gently towards + to browse through the menus until you reach the one you wish to review or change, then press down on the joystick to select it. The display will start flashing and you can make your change by pressing gently towards + or -. Finish by pressing the joystick down once to confirm your choice. You can then continue to review other menus by pressing the joystick towards + or -. Exit the menus by pressing the return button.

	<p>Menu 1 – [1rF] – link up to the remote control CT Put the remote control into LINK UP mode. On SF, press in and hold down the joystick until 1rF is displayed. Press the joystick lightly once and the thermostat shows the zone number chosen on the remote control. Link-up is now successful.</p>
	<p>Menu 2 – [2bP] – selecting the method of control The display shows bP, alternatively HYs.</p> <p>bP (proportional band) means that the thermostat switches on and off within a 1½ minute period. With little need for heat, the thermostat will switch off for a longer period and on for a shorter one. The opposite will apply when it is cold and the need for heating greater. Together, the on and off periods will always amount to 1½ minutes.</p> <p>Hys (hysteresis) means that the thermostat will switch off when the temperature reaches 0.5°C over the set temperature, and switch on again when it sinks to 0.5°C under the set temperature.</p>
	<p>Menu 3 – [3 0.0 °C] – calibration when the built-in sensor is selected If there is a large deviation between the set temperature and the actual room temperature, SM can be calibrated. If the room is too cold, calibrate using + to get a higher value than 0. If too warm, calibrate using – to get a lower value than 0. (Before calibrating, the room should be stable, i.e. the thermostat should have been in operation for at least 10–12 hours. Avoid airing the room and opening doors and windows or switching other heat sources on and off during this period. Under-floor heating is often sluggish to regulate, and it may take a longer period to achieve stability, often 24 hours or more with cables set in concrete.)</p>
	<p>Menu 4 – [4 0.0 °C] calibration when a floor sensor or wall-mounted sensor is selected If there is a large deviation between the set temperature and the actual room temperature, SM can be calibrated. If the floor (room) is too cold, calibrate using + to get a higher value than 0. If too warm, calibrate using – to get a lower value than 0. (Before calibrating, the room should be stable, i.e. the thermostat should have been in operation for at least 10–12 hours. Avoid airing the room and opening doors and windows or switching other heat sources on and off during this period. Under-floor heating is often sluggish to regulate, and it may take a longer period to achieve stability, often 24 hours or more with cables set in concrete.)</p>
	<p>Menu 5 – [5 Sen] – selecting sensor(s). Select both for limiting the temperature in wooden flooring The choice of wall-mounted or floor sensor is shown by the symbol for floor sensor. If you choose the floor sensor when no such sensor is connected, you see an error report, Err. Connect an external sensor, or go to the menus and make another selection.</p>

	<p>Menu 6 – [6L18] – setting the lowest temperature for a floor sensor or wall-mounted sensor Select the lowest desired temperature for where the sensor is situated. (Range: 5°C up to 1°C under that which is selected as the maximum temperature limit.)</p>
	<p>Menu 7 – [7 H28] – setting the maximum temperature for a floor sensor (or wall-mounted sensor) – used to avoid damage to wooden and parquet flooring from too high temperatures. Set the highest possible temperature that may be reached where the sensor is situated. Clarify with the flooring supplier what the recommended maximum temperature is. This is often 28°C for wooden floors and parquet. (Range: from 1°C over the minimum set point chosen in menu 6, up to 40°C.)</p>
	<p>Menu 8 – [8 CL0] – compensating for various outputs For the best regulation when using the internal sensor, the thermostat must know how large an output the heating cable has. (The values shown under apply only to the floor thermostat SF where the load is controlled via an internal relay.)</p> <ul style="list-style-type: none"> 1 = 500–1000 watts 2 = 1000–1500 watts 3 = 1500–2000 watts 4 = 2000–2500 watts 5 = 2500–3000 watts 6 = over 3000 watts
	<p>Menu 9 – [9 FAC] – revert all settings to the factory default NB! This menu will revert all settings back to the factory default settings. If you do not know how values will be affected, do not use this menu without first studying the following:</p> <p>The default factory values are:</p> <ul style="list-style-type: none"> 1 = 1rF (no options) 2 = bB proportional band regulation 3 = 0.0°C calibration of built-in sensor 4 = 0.0°C calibration of floor sensor (wall sensor) 5 = built-in sensor 6 = minimum temperature limit 18°C 7 = maximum temperature limit 28°C 8 = compensated for output load under 500 watts 9 = FAC (no options)

Description of relay (SX-)

- 1 Main switch** (two-poled). When SX is switched on, all symbols are displayed, followed by s H1.0 [software version 1.0]. Then the zone number appears, followed by the relay status, currently OFF.
- 2 Return button.** By pressing the return button you may exit a menu and return to normal operation, with radio reception active even if manual control was previously selected.

Display overview. When you switch SX on, all symbols are displayed. Note that not all of these are relevant to SX.

- 1 Antenna, displayed when SX is listening for signals from the remote control.
- 2 Symbol shows that the menu is active, regarding the link-up function.
- 3 Shows the number of the current menu selection.
- 4 Hand symbol means that manual control is in operation.
- 5 Large characters show the zone number or the relay status, ON or OFF.
- 6 Indicator showing that the relay is currently switched on.
- 7 Key symbol indicates that the thermostat may only be regulated by the remote control.

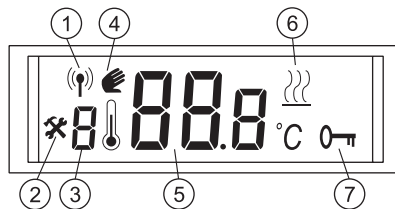
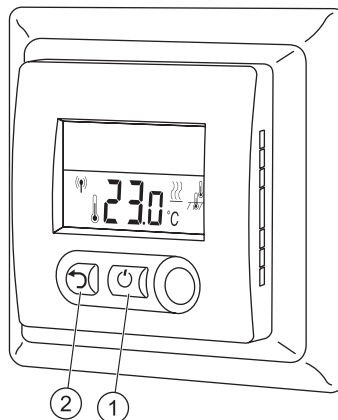

Choosing manual control

To go over to manual control, first press the joystick towards + for more than 5 seconds until the hand symbol appears. Release the joystick and press towards + or – to switch the relay on or off. This status will then continue until it is manually switched over, or until it is activated again by the remote control.

To return from manual override back to remote control, press the return button and the antenna symbol denoting remote control appears. The relay is again controlled by the remote control CT, which transmits signals every 12 minutes to keep all receivers updated.

Menu options



Menu 1 – [1rF] – link up to the remote control CT

For SX with programme version 1.0 [sF 1.0].

On SX, press in and hold down the joystick until the display shows the symbol 1rF. Press the joystick once and 1rF flashes. As long as CT is in link-up mode, SX will now link itself to CT and display first the selected zone, then the relay status, ON.

This is the only active menu for SX.

Description of the under-floor heating thermostat (CFG)

1. Main switch (0/1).

Is used to switch the under-floor heating on and off.

FI = internal, built-in sensor.

FE= external sensor (wall or floor).

2. Function key.

The function key “F” has several uses:

- To link up the thermostat to your CT-remote control. See the section on linking up.
- To make CFG receive commands from the remote control or not.
- To show zone linking. The display will show the zone number (1–16) for three seconds.

3. Lamp for radio reception.

When CFG is linked to CT- and the green lamp is lit, the thermostat is being regulated by CT-. When the lamp is dimmed, the temperature may be regulated on the thermostat using the ▲ and ▼ keys.

4. Local regulation of temperature.

If you wish to regulate the thermostat using its own controls, the green reception lamp must be dimmed (using the “F” key). Using the ▲ and ▼ keys, you may set the temperature as desired.

5. Lamp for “working”.

The red lamp lights when heating is on. The thermostat regulates between two temperature limits. Heating is turned on at appr. 1°C below the set temperature, and turned off at appr. 1°C over.

6. Display.

Shows the desired (set) room temperature, or the desired floor temperature when a floor sensor is used.

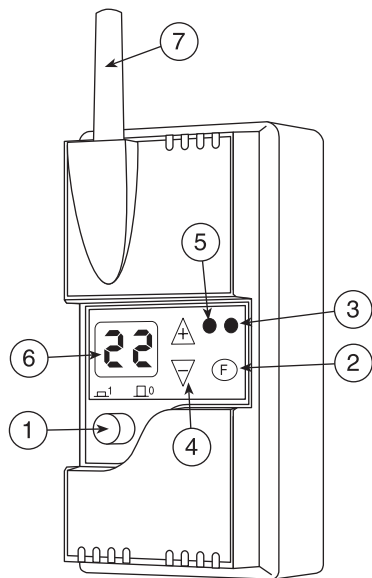

NB! (when using a floor sensor):

In most rooms in the home, the floor temperature should not exceed 28°C. In the bathroom 30°C may be allowed. This is to avoid drying out, cracks in wooden flooring, or discolouration of PVC covering.

7. Antenna.

8. Local variance.

If you desire a temperature setting permanently at variance with that set by CT-, do as follows:

Press in “F” and then \triangle while holding “F” in. The display will now flash. Release both keys. Now press the \triangle or ∇ key once for each °C you desire the variance to be (max. +/- 5°C). If you are adjusting an already set variance, the earlier variance will be displayed.

The thermostat will complete the procedure itself and after 15 seconds the flashing will stop.

Example: The CT- remote control is regulating several thermostats in different rooms in the same zone with 26°C as the desired floor temperature. In one of the rooms, this is experienced as a little cold. You may then use the variance setting procedure and add 2°C. The thermostat will then show 28°C even though CT- is transmitting 26°C.

9. Central locking

If, when operating the thermostat, it displays “--”, it is locked at CT- to prevent it being tampered with. May be cancelled only at CT-.

10. Correcting the thermostat

In the case of an internal or external sensor, the thermostat is calibrated like the CM- thermostat (against air temperature).

With floor sensor:

Start calibration when the floor is warmed through and at a stable temperature.

If there is a deviation between the floor’s surface temperature and the displayed temperature, you can correct this difference as follows: Press in “F” and then ∇ while still holding “F” in. The display will now flash. Release both keys. Alter the displayed temperature to match the measured temperature with the \triangle and ∇ keys. The thermostat completes the procedure itself and stops flashing after 15 seconds.

Example:

The thermostat shows 28°C, while the actual floor temperature is 25°C. The thermostat must, in this case, be corrected from 28°C down to 25°C using the ∇ key.

Description of the wall-mounted master thermostat (CM-)

1. Main switch (0/1).

Used to switch heating on and off. For the first three seconds the display shows which sensor is active.

FI = internal, built-in sensor.

FE= external wall-mounted sensor.

2. Function key.

The function key “F” has several uses:

- To link up the thermostat to your CT-remote control. See the section on linking up.
- To make CM- receive commands from the remote control or not.
- To show zone linking. The display will show the zone number (1–16).

3. Lamp for radio reception.

When CM- is linked to CT- and the green lamp is lit, the thermostat is being regulated by CT-. When the lamp is dimmed, the temperature may be regulated by CM- itself using the Δ and ∇ keys.

4. Regulating temperature locally.

If you wish to set the temperature using the controls on CM-, the green lamp for radio reception must be off (use the “F” key) You may now set the temperature using the Δ and ∇ keys.

5. Lamp for “heating”.

The red lamp is lit when heating is on. The thermostat regulates between two temperature limits. Heating is turned on at appr. 1°C below the set temperature, and turned off at appr. 1°C over.

6. Display.

Shows the desired temperature setting.

7. Antenna.

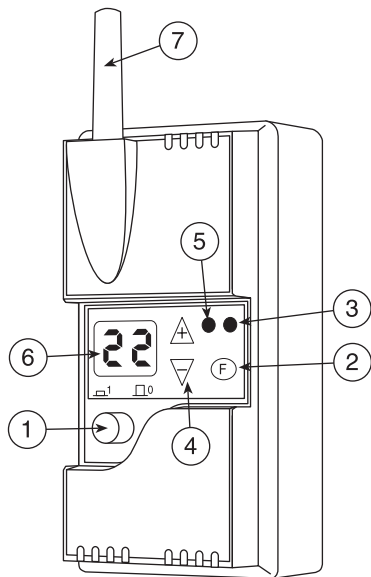

8. Local variance.

If you desire a temperature setting permanently at variance with that set by CT-, do as follows:

Press in “F” and then \triangle while holding “F” in. The display will now flash. Release both keys.

Now press the \triangle or ∇ key once for each °C you desire the variance to be (max. +/- 5°C). If you are adjusting an already set variance, the earlier variance will be displayed.

The thermostat will complete the procedure itself and after 15 seconds the flashing will cease.

Example: The CT- remote control is regulating several thermostats in different rooms in the same zone with 22°C as the desired room temperature. In one of the rooms, this is experienced as a little cold. You may then use the variance setting procedure and add e.g. 2°C. The thermostat will then show 24°C even though CT- is transmitting 22°C.

9. Central locking.

If, on attempting to operate, the thermostat displays “-” for three seconds, it is locked centrally at CT- to prevent tampering. May only be cancelled at CT-.

10. Correcting the thermostat.

Correction (calibration) of the thermostat must be carried out when the room is at a stable temperature, i.e. when the red lamp goes on and off at regular intervals. If there is a deviation between the temperature shown by the display and that measured in the room, it may be corrected as follows:

Press in “F” and then ∇ while still holding in “F”. The display will start to flash. Release both keys. Correct the displayed temperature to match room temperature using the \triangle and ∇ keys. The thermostat will complete the procedure itself and stop flashing after about 15 seconds.

Example: The thermostat shows 22°C, but a room thermometer shows 20°C. The thermostat must here be adjusted down from 22°C to 20°C using the ∇ key.

Description of the relay unit (CXG)

1. Main switch (0/1).

2. Function key.

The function key “F” has several uses:

- To link up the relay unit to your CT-remote control. See the section on linking up.
- To make CXG receive commands from the remote control or not.

3. Lamp for radio reception.

When CXG is linked up to a zone, and the green lamp is lit, the unit is being regulated by the CT- remote control. When the green lamp is off, the relay may be switched on and off using the \cap key.

4. Local control.

If you wish to operate the relay by its own controls, the green lamp must first be dimmed (using the “F” key). You may now switch the relay on and off by means of the \cap key.

5. Lamp for on/off.

The red lamp over the \cap key lights when the relay is switched on.

6. Antenna.

7. Reviewing zone linking.

The zone linking can be controlled by pressing in the “F” key and then the \cap key while still holding in “F”. Release both keys. The red lamp (\cap lamp) will flash a number of times denoting the number of the zone the unit belongs to.

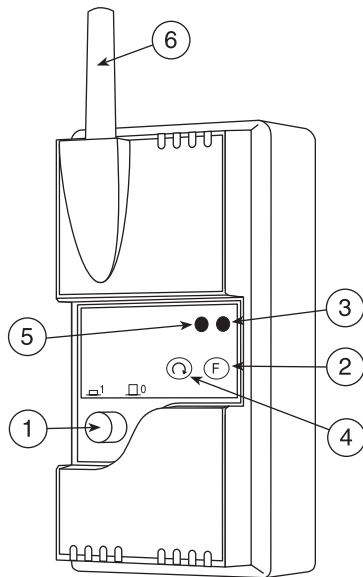

1 flash = relay zone 17
2 flashes = relay zone 18
...and so on up to...
8 flashes = relay zone 24

8 Central locking.

If, upon trying to operate it, the relay shows only flashing lamps (both lamps flash for appr. five seconds), it is locked centrally at CT- to avoid tampering. May only be cancelled at CT-.

Description of the heater thermostat (CR-)

1. Main switch (0/1).

The switch is situated on the heater.

2. Function key.

The function key has several uses:

- To link up the thermostat to the CT- remote control. See the section on linking up.
- To make the thermostat receive signals from CT-, or not.
- To show zone linking. The display will show the zone number (1–16).

3. Lamp for radio reception.

When the green lamp is lit, the thermostat is being regulated by CT-. When the lamp is dimmed, the temperature can be regulated using the Δ and ∇ keys.

4. Regulating temperature locally.

If you wish to override CT- and set the temperature by means of the thermostat's controls, the green lamp for radio reception must be off (using the "F" key). The temperature may now be set using the Δ and ∇ keys, as desired.

5. Lamp for "working".

The red lamp shows when the heater is switched on. The thermostat makes adjustments at periods of appr. 40 seconds. E.g., if the heater must work about 50% of the time to maintain the temperature, the lamp will be on for about 20 seconds and off for 20 seconds.

6. Display.

Shows the desired set temperature in °C.

7. Antenna.

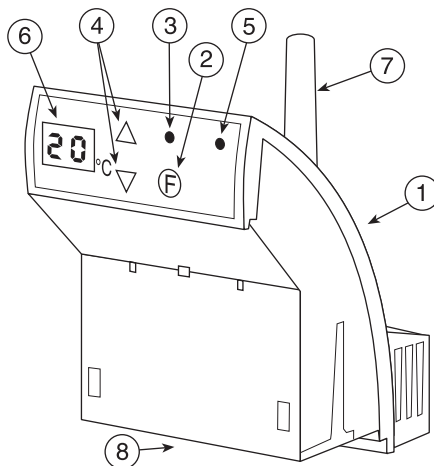

8. The catch mechanism locking the thermostat to the heater.

In order to loosen the thermostat from the heater, a small screwdriver, ballpoint pen or similar is required. The locking tab is released and the thermostat is pulled/tilted out.

9. Local variance in temperature.

If you desire a temperature setting permanently at variance with that set by CT-, do as follows:

Press in “F” and then \triangle while still holding “F” in. The display will now flash. Release both keys.

Now press either the \triangle or ∇ key, once for each °C you desire the variance between the thermostat and CT- to be. The thermostat will complete the procedure itself and after 15 seconds the flashing will cease.

Example: The CT- remote control is regulating several thermostats in different rooms in the same zone with 22°C as the desired floor temperature. In one of the rooms, this is experienced as a little cold. You may then use the variance setting procedure and add e.g. 2°C using the \triangle key. The thermostat will then show 24°C even though CT- is transmitting 22°C.

10. Correcting the thermostat.

Correction (calibration) of the thermostat must be carried out when the room is at a stable temperature, i.e. when the red lamp goes on and off at regular intervals. If there is a deviation between the temperature shown by the display and that measured in the room, it may be corrected as follows:

Press in “F” and then ∇ while still holding in “F”. The display will start to flash. Release both keys. Correct the displayed temperature to match room temperature using the \triangle and ∇ keys. The thermostat will complete the procedure itself and stop flashing after about 15 seconds.

Example: The thermostat shows 22°C, but a room thermometer shows 20°C. The thermostat must here be adjusted from 22°C down to 20°C using the ∇ key.

Brief description of the system

The CT- remote control is designed to regulate electric heating products and other electric appliances that are to be switched on and off.

CT- communicates with thermostats and relays via 433.92 MHz radio signals.

All the linked heating and relay units are adjusted by CT- every time programming dictates this, and updates are transmitted approx. every five minutes.

After a power cut, temperature settings will revert to 22°C and relays are switched off (default values) until the next time CT- transmits an adjustment.

The CT- remote control regulates up to 16 heating zones and 8 relay zones.

The remote control and related products

The remote control may be programmed to automatically regulate temperature in different rooms, and to switch on and off electric appliances.

Information is transmitted via radio signals to the various units, so that different rooms at different times receive instructions as to what

temperature setting is desired, or that lights are to be switched on or off.

Heaters or wall-mounted thermostats display the currently chosen temperature with clear illuminated figures.

Even if several transmitters are working in close vicinity to each other, only the remote control and the units that belong to it, will affect one another. There is no possibility that your neighbour's system will interfere with yours.

During normal working conditions, the remote control is placed in a holder/charger that is coupled to a 230 V supply. CT- will then always have fully charged batteries and may, for periods of three to four days, be used as a mobile unit.

Zone

- A room with any number of heaters, wall-mounted thermostats or relay units.
- Several rooms with any number of heaters where all the rooms are to maintain the same temperature at the same times.
- Note: heating regulation: zones 1 to 16, relay regulation (on/off): zones 17 to 24.

Normal temperature

- The desired temperature for when the room is in use.

Economy temperature

- The desired temperature for when the room is not in use, or at night while you sleep. CT- suggests 17°C.

Column chart

The column chart provides two kinds of information: Normal or economy temperature settings, and on/off periods, that have been chosen at different times.

1. Tall and short columns

Normal temperature, and when relays are switched on, is denoted by tall columns in a 24-hour diagram. Economy temperature, or when relays are switched off, is denoted by short columns.

2) Daily cycle of temperature or relay-on/off

The chart has 24 columns, one for each hour of the day. The first column from the left represents the hour from 00:00 (mid-night) to 01:00 (1 a.m.).



Explanation of terms used

Menu

When the system is operating normally, this is shown in the display.

Displayed is the day of the week (1 = Monday), the time and “MENU”.

See/change programme

Is used if you wish to review the current daily cycle for a zone or day. You may make changes to the daily cycles or temperature settings.

Temporary override



Is used during e.g. holidays. You may set a specific temperature or switch off relays for a specified period. Limited to 99 days and 99 hours.

Link up

Before thermostats or relays can be regulated by CT-, a procedure must be undertaken to link each receiver to the transmitter in your CT-. When this is done, only your CT- may control the units in question. During linking up, the CT- remote control must be taken around to where the various thermostats are situated – and the batteries in CT- must therefore be fully charged.

Maintenance

This menu allows you to:

- Choose a language.
- Set the correct time and day.
- Activate, deactivate or change the Pincode. The Pincode is used to hinder unauthorised operation. 0000 has been set as the code by the factory. This may be changed as desired (four digits).
- Central locking which prevents thermostats or relays being tampered with.
- Choose whether your CT- is in normal or office mode. Choosing office mode makes the red hot-key  change its function. By pressing the  key, all the heating zones will go to normal temperature for five hours. This is a useful function when working overtime.
- Check which version of the software that is installed (CT- may be upgraded).

New programme

Allows you to set the daily cycle for normal and economy temperature for each zone, day by day. For relay units, the cycle switching on and off is set.

Delete programme

Programmes for zones not in use may be deleted.

See zone status

Pressing  will give you information on:

- Heating zones. Tall columns represent zones that are programmed (column 1 from the left shows zone 1, column 2 shows zone 2, and so on). Tall columns that are flashing denote zones that are currently at economy temperature.

Pressing  once more returns you to “MENU”.



Hot-keys

These are used if you wish to manually override some or all heating/relay zones. You must remember to cancel this function yourself.

The  key sets normal temperature, or switches relays on. Choose whether all or just certain zones are to be overridden.

The  key sets economy temperature, or switches relays off. Again, choose whether all or just certain zones are to be overridden.

Auto key

Besides showing the zone status, the  key is used to return to “MENU”, wherever you are in the remote control’s menus. Pressing  while you are in the middle of making or changing a programme means that anything entered will not be stored.

